

USER REFERENCE MANUAL
for Aria™ Software

OCTEL MESSAGING DIVISION

THE POWER OF MESSAGING

Voice messaging gives you the ability to communicate effectively from any touchtone phone 24 hours a day, with one person or many. In a single call you can:

- Send messages and send copies of messages to others
- Review, reply to and save voice and fax messages sent by your callers
- Record a single detailed message and distribute it to dozens of colleagues
- Print faxes you have received to any fax device (if you have the fax feature)

With the Octel® system, your schedule—and that of your colleagues—no longer affects your ability to communicate. You can take advantage of a business tool that lets you accomplish more in less time. This is the power of messaging.

You can use the Octel system to send and receive messages simply by entering your voice and fax mailbox and following the directions you will hear. This manual supplements the spoken directions and describes the use of special features of the Octel system. It explains how to:

- Enter, set up and exit your voice and fax mailbox
- Record a message, address it to one or more recipients and select delivery options such as urgent, private or future delivery
- Retrieve messages sent to you and respond to them by saving, sending a copy, deleting or sending a message in reply
- Send and receive fax messages
- Locate messages sent to you or that you have sent to a specific user or group of users
- Set up custom options such as greetings, group distribution lists and outcall notification schedules
- Use optional features of the Octel system—for example, to record meetings, send broadcast messages and access applications
- Explain the system to callers

CONVENTIONS

- 5 Numbers appearing in clear boxes are keys that you press on your telephone keypad. For example, 5 means press the number 5 key; * - 5 means press the star key at the bottom left of your keypad; then press the 5 key.
- 5 Numbers appearing in solid boxes are choices that you select from the main menu, which is the first set of prompts you hear when you enter your mailbox. To go to the main menu at any time during a session, press * one or more times until you hear the words “main menu.”
- ◇ Features marked with the symbol ◇ are optional features that may not currently be available on your system or in your mailbox. Some must be enabled by the system manager; others may be enabled by you (*see Chapter 7, “Managing Your Mailbox”*).

CONTENTS

1 Entering and exiting the system	1	7 Managing your mailbox	39
Setting up your Octel mailbox	2	Creating and changing greetings	41
Entering the system	3	Creating and changing passwords	44
Exiting the system	4	Creating and managing personal group lists	47
2 Using power keys	5	Selecting prompt level	49
Cancelling with the [*] key	6	Setting up a notification schedule	50
Getting help with the [0] key	7	Turning outcall notification on or off	53
Ending a step with the [#] key	8	Turning message notification on or off	54
3 Recording and sending voice messages	9	Setting date and time playback	55
Recording voice messages	11	Forwarding messages to mailboxes on other systems	56
Using recording controls	12	Activating access security	58
Addressing the message	13	8 Using special features	59
Selecting delivery options	14	Accessing applications	60
Sending the message	17	Reviewing and sending Bulletin Broadcast™ messages ..	61
Using voice mail effectively	18	Recording a meeting	65
4 Listening and responding to voice messages	19	Sending messages to large groups of people	68
Listening to messages	21	Sharing a telephone	73
Responding to messages	24	Sending messages outside your company's network	78
Using playback controls	27	9 Explaining the system to outside callers	79
5 Sending and receiving fax messages	29	Sending fax messages	80
Selecting fax options	30	Leaving voice messages	82
Reviewing, responding to and printing fax messages	32	Glossary	83
Telling callers how to send a fax to you	34	Index	85
6 Locating messages you have sent or received	35	Aria At-A-Glance	Back
Locating messages you have sent	37		
Locating messages you have received	38		

CHAPTER 1

ENTERING AND EXITING THE SYSTEM

In this chapter:

- Setting up your Octel mailbox
- Entering the system
- Exiting the system

To begin using the Octel system, you need the following information:

- The phone number for the Octel system
- Your mailbox number
- The temporary password

To enter your mailbox for the first time and change your temporary password to a personal password:

- ▶ Call the Octel system telephone number
- ◊ ▶ Press **#** to indicate that you have a mailbox on the system
- ◊ ▶ Enter your mailbox number

NOTE: *The above two steps are not required if your extension is integrated with your mailbox. See your system manager if you have questions.*

Follow the spoken instructions to set up your mailbox:

- ▶ Enter your temporary password
- ▶ Enter a new password containing up to 15 digits
- ▶ State your name as you want it to be announced to people who address messages to your mailbox
- ▶ Press **#** to accept the name as recorded, or press ***** to record your name again
- ▶ Press **1** to choose a standard greeting or press **2** to record a personal greeting, which gives your callers more information
- ▶ Record your greeting
- ▶ Press **#** to accept the greeting as recorded, or press ***** to record your greeting again
- ▶ Listen to recorded tips about using your mailbox
- ◊ ▶ Listen to information about the fax feature

You may now send and receive messages via your mailbox.

ENTERING THE SYSTEM

Entering your mailbox from your office phone

- ▶ Call the internal Octel system phone number
- ◊ ▶ At any time during the greeting, press **#** to indicate that you have a mailbox on the system
- ◊ ▶ Enter your mailbox number
- ▶ Enter your password

The system prompts you to select an action. To change the level of detail in the prompts, see *"Selecting prompt level," page 49*.

Entering the system from outside the company

You can call the Octel system from any touch-tone phone, anywhere in the world.

To enter your mailbox from outside the company:

- ▶ Call the Octel system phone number
- ▶ At any time during the greeting, press **#** to indicate that you have a mailbox on the system
- ▶ Enter your mailbox number
- ▶ Enter your password

You can now make choices from the main menu.

TIP: Making credit card calls

*If you call the Octel system using a telephone credit card and you press **#** too quickly, the telephone company may interpret your action to mean you want to place another credit card call. To avoid this, press ***#** instead of **#** to indicate that you have a mailbox on the system. Or, wait until the system's introductory prompt is finished before you press **#**.*

Exiting the system entirely

To exit the Octel system, press **✱** until you reach the main menu, then press **✱** to exit.

Restarting

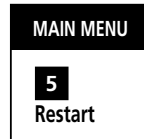

After you have finished sending and reviewing messages, you may want to restart—that is, exit your mailbox but remain in the Octel system. Then you can perform tasks unrelated to your mailbox—for example:

- Use an automated attendant to transfer to an extension
- Listen to information in an application mailbox

To restart:

- ▶ Return to the main menu
- ▶ Select Restart

5

CHAPTER 2

USING POWER KEYS

In this chapter:

- Cancelling or going back with the ***** key
- Getting help with the **0** key
- Moving to the next step with the **#** key

Press  when you want to cancel what you are doing:

- Erase and rerecord
- Re-enter a destination number if you have made a mistake
- Back up to the previous menu
- Exit from the main menu

GETTING HELP WITH THE **0** KEY

Press **0** when you need help, more explanation or want more options. If you don't press any key when prompted, the system will repeat the previous options.

To reach an attendant if one is available, press **0** – **0**.

If you hear the message, “Sorry, you're having trouble,” you are experiencing difficulty requesting an option or you have pressed **0** several times. If you don't get the help you need by pressing **0**, first look for the answer in this manual, then check with your system manager.

Press # to proceed immediately to the next step—for example:

- Enter your mailbox as soon as the system greeting begins playing
- Skip a prompt if you already know what you want to do
- Terminate a recording—for example, your name or personal greeting
- Denote the end of a variable-length number such as a password, telephone number or group list number

CHAPTER 3

RECORDING AND SENDING VOICE MESSAGES

In this chapter:

- Recording voice messages
- Addressing voice messages
- Selecting delivery options
- Sending voice messages
- Using voice mail effectively

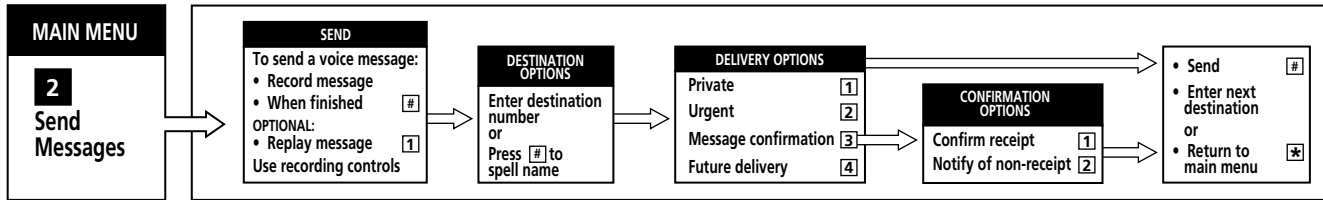

RECORDING VOICE MESSAGES

Recording a voice message

- ▶ Select Send Messages 2
- ▶ Record the message
(See the table on page 12 for recording controls)
The system beeps twice if only 10 seconds of recording time remain
- ▶ When finished recording #
- ▶ Replay the message before sending (optional) 1

Rerecording the message

If you are not satisfied with your message, you can rerecord all or part of it any time before sending.

To rerecord the entire message:

- ▶ Erase and prepare to rerecord *
- ▶ Record the message
- ▶ When finished recording #

TIP: Pausing while recording

To pause at any time while recording, press **2**.
To resume, press **2** again.

To rerecord a portion of the message:

- ▶ Rewind or fast forward to the portion you wish to record over *(see table on page 12)*
- ▶ Indicate you are ready to record 5
- ▶ Record over the remaining portion of the message
- ▶ When finished recording #

After recording the message

- ▶ Address the message *(see page 13)*
- ▶ Select delivery options *(see page 14)*
- ▶ Send the message *(see page 17)*

<u>To do this</u>	<u>Press these keys</u>
Delete the entire message and rerecord	*
Rewind 10 seconds	1
Rewind to beginning	1 - 1
Pause for about 20 seconds or resume	2
Fast forward 10 seconds	3
Fast forward to end	3 - 3
Begin recording after a pause	2

RECORDING CONTROLS			
	REWIND	PAUSE/ RESTART	FORWARD
Position	1	2	3
	4	5	6
	7	8	9
	CANCEL	HELP	SKIP
	*	0	#

ADDRESSING THE MESSAGE

Send messages to any combination of the following destinations:

- On-system user
- ◇ • Network user
- ◇ • Personal group list (*see page 47*)
- ◇ • System distribution list, maintained by your system manager
- ◇ • Guest or home mailbox (*see page 44*)

Entering a mailbox number or distribution list number

Enter a single mailbox number or distribution list number (personal or system). The system tells you the name of the person or distribution list.

After entering the number, select delivery options (*see "Selecting delivery options," page 14*) or press **#** to send.

After you press **#** to send, the system prompts you to enter additional destinations for the same message or press ***** to return to the main menu.

◇ Spelling a name using Dial-by-Name

If you don't know a user's mailbox number, press **#**, then spell the person's name, last name first, as follows:

A, B, C	=	2
D, E, F	=	3
G, H, I	=	4
J, K, L	=	5
M, N, O	=	6
P, Q, R, S	=	7
T, U, V	=	8
W, X, Y, Z	=	9

For example, to address a message to Smith, Ann, enter **76484266**. You must spell the name exactly as the system manager entered it on the system.

When you have entered enough characters to uniquely identify a user's name, the system states the name. If more than one name matches the characters you have entered, the system presents those names and asks you to select one.

You may select any combination of delivery options:

- Private
- Urgent
- Message confirmation
- ◇ • Future delivery

Select options after you address the message and before you press **#** to send.

To cancel an option for a particular destination, press its number again before sending the message. For example, press **2** to mark a message urgent, then press **2** again to remove the urgent marking.

TIP: Selecting different delivery options for different destinations

*If you send a message to multiple destinations, the delivery options you select for the first destination automatically apply to additional destinations. To turn them off, press the number of the option again before sending the message to the second destination. For example, to mark a message as urgent to two recipients and mark it for future delivery to a third person, you would enter **2** before sending the message to the first recipient, enter nothing before sending the message to the second recipient, and enter **2** (to turn off the urgent marking) and **4** (to turn on future delivery) before sending the message to the third recipient.*

Marking a message as private **1**

Private messages cannot be forwarded by the recipient to anyone else. The system informs the recipient that the message is private.

Marking a message as urgent 2

Urgent messages are played before non-urgent messages. The system informs the recipient that the message is urgent.

TIP: Use the urgent delivery option with discretion

Some users set up the system to notify them immediately when urgent messages are received (see “Setting a notification schedule,” page 50).

Do not mark routine messages as urgent.

Requesting message confirmation 3

The system offers two types of message confirmation: confirmation of receipt and notification of non-receipt.

To request confirmation of receipt:

- ▶ Select Message Confirmation 3
- ▶ Select Confirmation of Receipt 1

The system sends a message to your mailbox telling you when the recipient has listened to the entire message.

To request notification of non-receipt:

- ▶ Select Message Confirmation 3
- ▶ Select Notification of Non-Receipt 2

The system notifies you if the recipient does *not* listen to your message within the time frame that the system manager has specified.

◇ Requesting future delivery 4

Future delivery messages are messages that you record for later delivery to another mailbox. They are placed in the recipients' mailboxes until the delivery time, although they are not notified about them, nor can they hear them.

To specify future delivery:

- ▶ Select Future Delivery 4
- ▶ Specify the delivery date 1
 - Enter the month—for example,
1 for January or 1 2 for December
 - Enter the day of the month—for example,
3 1 for the 31st
 - Enter the hour and minute—for example,
2 0 0 for 2:00 or 1 0 1 5 for
10:15
 - Enter 1 for a.m. or 2 for p.m.

or

- ▶ Specify the delivery day 2

Spell the first two letters of the day of the week using the letters on the telephone keypad (see "Spelling a name," page 13).

For example, spell TU (Tuesday) by pressing 8 - 8.

Enter the hour and minute—for example,

2 0 0 for 2:00 or 1 0 1 5 for 10:15

Enter 1 for a.m. or 2 for p.m.

TIP: Sending to recipients in different time zones

If, for example, your time zone is three hours earlier than that of the recipient, subtract three hours from the desired delivery time. If your time zone is three hours later than that of the recipient, add three hours to the desired delivery time.

SENDING THE MESSAGE

Send the message after selecting delivery options.

To send a message to a mailbox on your local Octel system or on remote Octel systems:

- ▶ Enter the mailbox number or press **#** to spell the recipient's name
 - ▶ Select message delivery options (optional)
 - ▶ Send the message **#**
 - ▶ Enter another mailbox number or press **#** to spell the recipient's name
- or
- ▶ Return to the main menu *****

NOTE: *Just as a letter placed in a postal box cannot be retrieved, a message cannot be retrieved once it is sent.*

TIP: When the destination mailbox is full

When you try to send a message, you may be informed that a mailbox is full because it contains the maximum allowed number of messages or future delivery messages. In this case, you must try later.

Like any form of communication, voice mail is an art. Follow these guidelines to use voice mail most effectively.

- Identify yourself and the topic at the beginning of the message.
- Address only one or two topics per message.
- State the key point early. Don't surprise the user at the end of the message.
- Be brief. Rerecord if you think your message is too long or confusing.
- Keep content appropriate for business.
- Talk face-to-face or write a memo if the topic is sensitive or complex.
- If the distribution list is long, name the recipients at the end.
- Use the urgent delivery option with discretion.
- Reply promptly to messages.
- Make your requests for information complete and concise so the recipient can respond via voice mail.

CHAPTER 4

LISTENING AND RESPONDING TO VOICE MESSAGES

In this chapter:

- Listening to voice messages
- Responding to voice messages
- Using playback controls

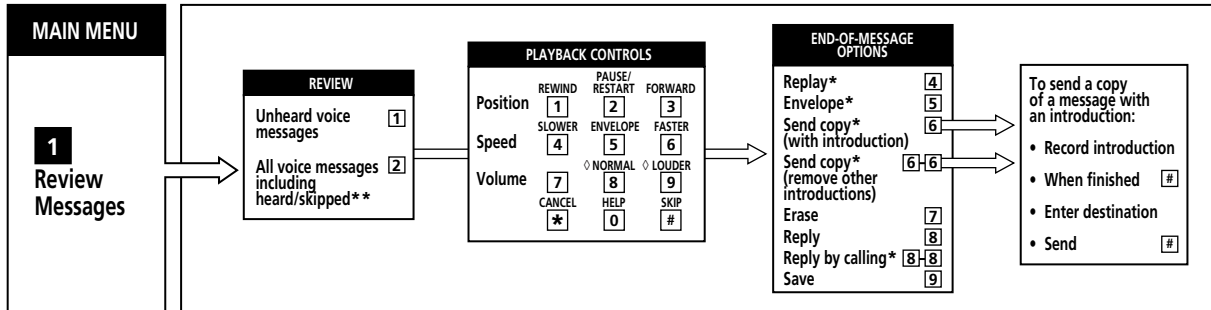

* The system does not prompt you for this option.

** The system prompts you for this option only if you have a fax mailbox.

LISTENING TO MESSAGES

Hearing the number of messages in your mailbox

After any special notifications and messages are played (see “Hearing special notifications and messages,” page 23), the system tells you the number of new and old archived messages in your mailbox.

- New messages include unheard messages and messages you have heard but skipped.
- Old archived messages are messages you have heard and saved.

Reviewing unheard voice messages

Unheard messages are those received since the last time you listened to messages or messages you skipped after hearing just a few words.

They are played in the following order:

- ◇ • Unheard home messages (see “Home password,” page 44)
 - Other unheard messages
 - New messages that arrive while you are listening to other messages

Within each category, messages are played in the order received, urgent messages first.

To review unheard voice messages

- ▶ Select Review Messages **1**
- ▶ Select Unheard Voice Messages **1**

Reviewing all voice messages

All voice messages, including those you have heard previously but skipped, are played in the following order:

- ◇ • Home messages (see “Home password,” page 44)
 - Other unheard and skipped messages
 - Heard but skipped
 - Archived messages

Within each category, messages are played in the order received, urgent messages first. Archived messages are played in the order archived.

To review all voice messages:

- ▶ Select Review Messages **1**
- ▶ Select All Voice Messages Including Heard and Skipped **2**

Skipping messages

Skip to the next message at any time by pressing **#**. Skip to archived messages—those you saved—by pressing **#** - **#**.

Cancelling review

Press ***** to cancel message review and return to the main menu. Messages that you did not review are available for review the next time you enter your mailbox.

Replaying a message

Replay a message by pressing **4** at the end of the message.

Obtaining envelope information

Envelope information includes the following information:

- Date and time sent or \diamond archived
- Sender (user name, \diamond telephone number of the calling party or “outside caller”)
- Length
- Status: urgent or private

To obtain envelope information, press **5** while listening to the message or immediately after it ends. After playing the envelope information, the Octel system resumes playing messages.

Hearing special notifications and messages

When you enter your mailbox, you might hear the following types of notifications and messages. You cannot skip them.

- Periodic instructions to change your password
- Broadcast messages
- ◇ • Unsuccessful outcall attempts—that is, attempts to notify you that messages were in your mailbox
- Confirmation of delivery (see “Requesting message confirmation,” page 15)
- Notification about deletion of one or more of your messages because they had been in your mailbox longer than your system manager allows

If your system allows you to send messages over the network to another Octel system, you may hear the following additional notifications:

- Non-delivery of messages due to networking difficulties
- Delivery of messages to users with extended-absence greetings
- Non-delivery of messages to users with extended-absence block

NOTE: *If you receive multiple notifications in any of these categories, the system combines them by category. You may listen to them individually or delete the entire category.*

Voice mail is most effective if you respond to all messages immediately after hearing them. If your callers have requested information that you do not have, let them know when you will have the information or refer them to someone who can help.

Replying with a voice message

You can reply to a user's message immediately after you review without hanging up and redialing.

To reply:

- ▶ Select Reply 8
- ▶ Record your reply
- ▶ When finished recording #
- ▶ Send the message #

◇ Replying by calling the sender

If the sender has an extension on your phone system, you can call the extension by pressing 8 – 8. The system immediately transfers you.

The message to which you just responded will remain in your mailbox as a skipped message.

- ◇ If the person does not answer the call, the system returns you to your mailbox and repeats the end-of-message options for the message.

Sending a copy

Send a copy of a voice message when others should hear it. Add an introduction so the person receiving the copy knows you forwarded it. You can send a copy of any message unless it has been marked private by the sender (see “*Selecting delivery options*,” page 14).

To send a copy after listening to the message:

- ▶ Select Send Copy **[6]**
- ▶ Record your introduction
- ▶ When finished recording **[#]**
- ▶ Review message before sending (optional) **[1]**
- ▶ Enter the destination mailbox or press **[#]** to spell the recipient’s name

◇ Sending a copy without other introductions

You may receive messages with several introductions—for example, John sent a message to Susan, who copied it to Robert, who copied it to you. You can optionally remove other users’ introductions before sending a copy with your introduction. If you do, the recipient hears the original message with your introduction only.

To send a copy without other introductions:

- ▶ Select Send Copy Without Other Introductions **[6] – [6]**
- ▶ Record your introduction
- ▶ When finished recording **[#]**
- ▶ Review message before sending (optional) **[1]**
- ▶ Enter the destination mailbox or press **[#]** to spell the recipient’s name

NOTE: You cannot remove other introductions from networked voice messages.

Erasing a message

- ▶ Select Erase 7

NOTE: *Erased messages cannot be retrieved.*

Saving a message

- ▶ Select Save 9

Messages that you save are stored separately from new messages and played after new messages.

Saved messages remain archived until you erase them by pressing 7 or they have been in your mailbox longer than your system manager allows.

USING PLAYBACK CONTROLS

While messages are playing, use the keys on your telephone to rewind, fast forward, pause or control the volume and speed of message playback.

To do this	Press these keys
Rewind 10 seconds	1
Rewind to beginning	1 - 1
Pause or resume	2
Fast forward 10 seconds	3
Fast forward to end	3 - 3
Slow playback speed	4 or 4 - 4 (slowest)
Hear envelope information	5
Accelerate playback speed	6 or 6 - 6 (fastest)
◊ Play at normal volume	8
◊ Play at louder volume	9

PLAYBACK CONTROLS			
Position	REWIND 1	PAUSE/ RESTART 2	FORWARD 3
Speed	SLOWER 4	ENVELOPE 5	FASTER 6
Volume	7	◊NORMAL 8	◊LOUDER 9
	CANCEL *	HELP 0	SKIP #

CHAPTER 5

SENDING AND RECEIVING FAX MESSAGES

In this chapter:

- Selecting fax options
- Reviewing, responding to and printing fax messages
- Telling callers how to send a fax to you

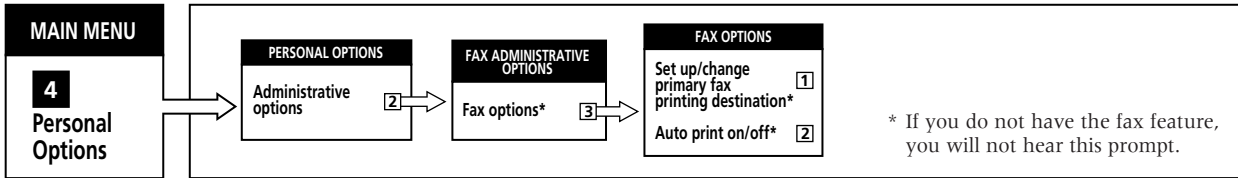

◇ Using the Octel system, you can hear about faxes that have been sent to your mailbox; then you can print them to any fax device.

◇ **Setting up a primary printing destination**

You may print faxes at any fax device. If you select the auto print option (*see page 31*), faxes always print at your primary destination. If you do not select the auto print option, you can specify that the faxes be printed at your primary destination or a destination that you supply.

To set up or change the primary printing destination:

- ▶ Select Personal Options **4**
- ▶ Select Administrative Options **2**
- ▶ Select Fax Options **3**
- ▶ Establish or change primary destination **1**
- ▶ Enter the fax phone number

◇ Specifying automatic printing of all faxes

The Octel system ordinarily stores all faxes until you give the order to print them; or you can choose to have the system print each fax message to the primary destination as soon as it is received.

To turn automatic printing on or off:

- ▶ Select Personal Options **4**
- ▶ Select Fax Administrative Options **2**
- ▶ Select Fax Options **3**
- ▶ Turn auto print on or off **2**

The system tells you whether auto print is on or off.

- ▶ Turn auto print on **1**
- or
- ▶ Turn auto print off **2**

When the system auto-prints a fax, the fax message remains in your fax queue as a new unheard message.

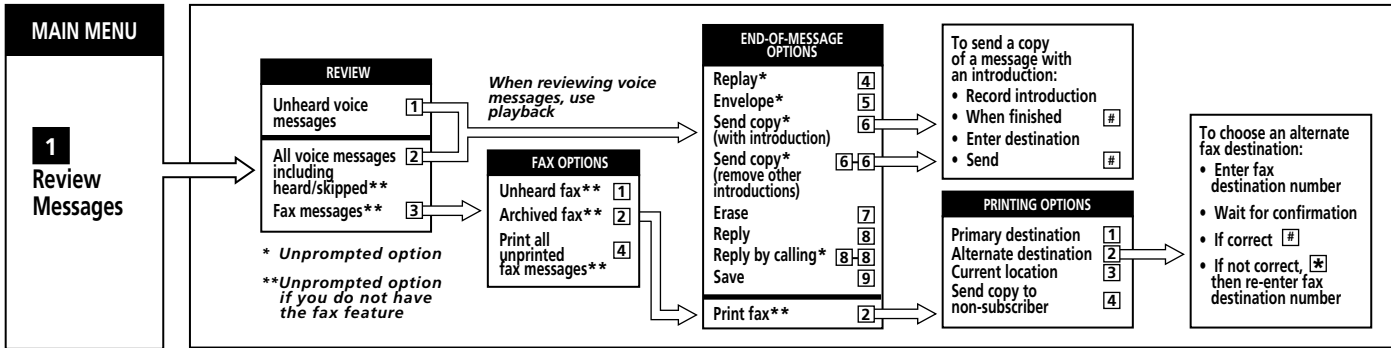

◇ Hearing about fax messages

- ▶ Select Review Messages 1
 - ▶ Select Fax Messages 3
 - ▶ Hear new or skipped fax messages 1
- or
- ▶ Hear archived fax messages 2

◇ Printing a fax message

- ▶ Select Print Fax 2
- ▶ Select destination:
 - Primary destination 1
 - Alternate destination 2
 - Enter fax telephone number
 - Fax device from which you are calling 3
 - Send copy to non-subscriber 4
- ▶ Select end-of-message options:
 - Erase 7
 - Reply 8
 - Save 9

Printing all unprinted fax messages

To print all unprinted fax messages to your primary destination:

- ▶ Select Review Messages 1
- ▶ Select Fax Messages 3
- ▶ Print all unprinted fax messages 4

(Map for this feature appears on page 80.)

- ◇ Callers can send a fax to your voice and fax mailbox. They also may record a voice message, or voice annotation, to precede the fax.

Voice annotations provide information about the fax without having to make notations on the fax itself. A caller can record a voice annotation and send the fax at the same time, or the caller can record and send them separately.

If the caller is going to send the fax separately, he or she records the voice annotation first using any telephone, not the fax device phone. In this case, the system gives a fax identification number to the caller. When sending the fax later, the caller must enter this identification number to link the fax and the voice annotation.

TIP: Remembering the fax identification number

Be sure to have a pencil handy when the system plays the fax identification number. Write down the number so you won't forget it.

To send a fax to a voice and fax mailbox from a fax device, the caller performs the following steps before placing the document in the feeder tray:

- ▶ Lift the handset of the fax machine
- ▶ Call or be forwarded to your mailbox
- ▶ During the greeting, press **4** for fax options
- ▶ Listen to the spoken prompts and follow directions

CHAPTER 6

LOCATING MESSAGES YOU HAVE SENT OR RECEIVED

In this chapter:

- Locating messages you have sent
- Locating messages you have received

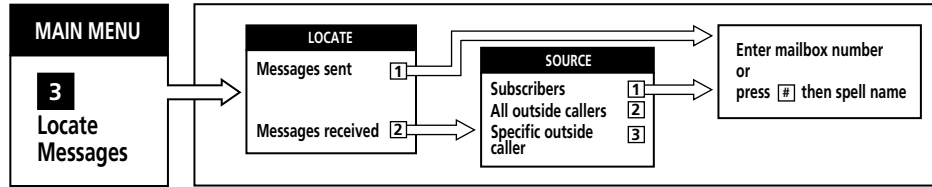

LOCATING MESSAGES YOU HAVE SENT

There are two ways to find out if a recipient has listened to your message in its entirety:

- Locate all unheard messages you sent to a particular user or distribution list, as explained in this section. A message is considered heard, or “listened to,” when the recipient has selected an end-of-message option for it.
- When sending, request that the system send you notification when the recipient has listened to your entire message (*see “Requesting message confirmation,” page 15*).

To locate messages you have sent:

- ▶ Select Locate Messages **3**
- ▶ Select Locate Messages Sent **1**
- ▶ Enter the user’s mailbox number or press **#** to spell the name.

The system plays messages you have sent but that have not been heard in their entirety by the recipient.

To skip a message, press **#**. To cancel the operation and return to the main menu, press *****.

- ◇ The Octel system will play messages sent to you from a user or distribution list you specify. This option enables you to locate messages from a particular user more quickly than you could if you listened to all messages.

◇ Locating messages sent to you from a specific user or personal group list

- ▶ Select Locate Messages **3**
- ▶ Locate messages received **2**
- ▶ Locate messages from a specific subscriber **1**
- ▶ Specify the sender by entering:
 - Mailbox number
 - Network address
 - Distribution lists
 - Home or guest mailbox number
 - Spell the user's name **#**

The system plays new and archived messages from the specified user or group of individuals on a list.

To skip a message, press **#**. To cancel the operation and return to the main menu, press *****.

◇ **TIP: Locating messages from a group of people**

If you want to locate messages from a group of individuals—for example, your project team—create the personal group list first (see “Creating personal group lists,” page 47). Then enter that group list number to locate messages from members of the group.

◇ Locating messages sent to you from outside callers

- ▶ Select Locate Messages **3**
- ▶ Select Locate Messages Received **2**
- ▶ Select Locate Messages From All Outside Callers **2**

The system plays new messages, then archived messages.

To skip a message, press **#**. To cancel the operation and return to the main menu, press *****.

◇ Locating messages sent to you from a specific outside caller

- ▶ Select Locate Messages **3**
- ▶ Select Locate Messages Received **2**
- ▶ Select Locate Messages From a Specific Outside Caller **3**
- ▶ Enter sender's phone number

The system plays the message.

CHAPTER 7

MANAGING YOUR MAILBOX

In this chapter:

- Creating and changing greetings
- Creating and changing passwords
- Creating and managing distribution lists
- Selecting prompt level
- Setting a notification schedule
- Turning outcall notification on or off
- Turning message notification on or off
- Setting date and time playback
- Forwarding messages to mailboxes on other systems
- Activating access security

In chapter 5:

- To select fax options, see page 30.

In chapter 8:

- To designate the application mailbox you want to hear, see page 60.

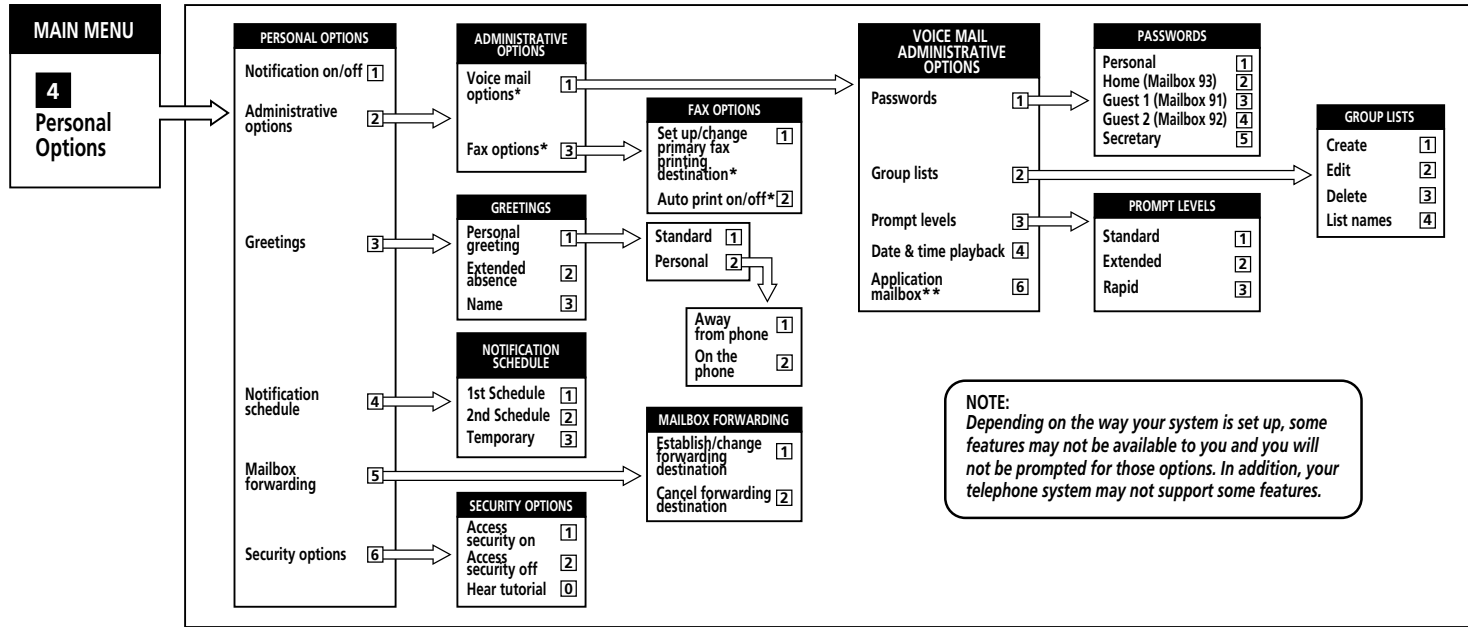

- * If you do not have the fax feature, you will not hear this prompt.
Fax options are explained in Chapter 5, "Sending and Receiving Fax Messages."
- ** Applications options are explained in Chapter 8, "Using Special Features."

CREATING AND CHANGING GREETINGS

Your greeting is played to anyone who phones or transfers to your mailbox. Use the personal greetings menu to change your personal greeting, record an extended-absence greeting or rerecord your name.

Types of greetings

You can select the standard greeting or create a personal greeting.

The standard greeting is:

“Your call has been forwarded to an automated voice message system. (*Your name*) is not available. At the tone, please record your message.”

- ◇ There are two types of personal greetings:
 - A greeting you record that plays when you do not answer your phone. In this greeting, inform callers that you are *away from your phone*.
 - ◇ ● A greeting you record that plays when you are on the phone. In this greeting, inform callers that you are *on the phone*. Ask your system manager if this feature is available on your system.

If you do not record a greeting for when you are on the phone, the system plays your away-from-your-phone greeting.

An example of a personal greeting is:

“Hello, this is (*your name*). You have reached my voice (*and fax*) mailbox. Today is (*date*). I’ll be in the office this morning, but in meetings all afternoon. If you want to send a fax, press four on your fax device, or please leave me a detailed message and I’ll return your call as soon as possible.”

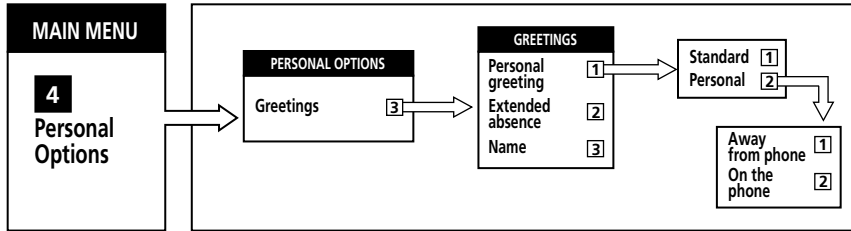

Recording a personal greeting

- ▶ Select Personal Options 4
- ▶ Select Greetings 3
- ▶ Select Personal Greeting 1
- ◊ ▶ Select Record a Personal Greeting 2
 - Select a greeting that plays when there is no answer, telling callers you are away from your phone 1
 - or
 - Select a greeting that plays when you are on the phone 2
- ▶ Record the greeting
- ▶ When finished recording #

Selecting the standard system greeting

- ▶ Select Personal Options 4
- ▶ Select Greetings 3
- ▶ Select Personal Greeting 1
- ▶ Select the standard system greeting 1

◇ Recording an extended-absence greeting

Record an extended-absence greeting to advise callers that you are away from the office and may be checking your mailbox infrequently. Give your callers the option of leaving a message or calling someone whom you designate. Callers cannot skip your extended-absence greeting.

◇ **TIP: Blocking messages during extended absences**

You can optionally block all messages other than system messages and bulletin broadcasts when the extended-absence greeting is on. Ask your system manager to enable the message block feature for you.

The system reminds you that your extended-absence greeting is on each time you enter your mailbox and prompts you to delete or retain it. Your personal greeting is reinstated when you delete the extended-absence greeting.

To record an extended absence greeting:

- ▶ Select Personal Options **4**
- ▶ Select Greetings **3**
- ▶ Select Extended-Absence Greeting **2**
- ▶ Record the greeting
- ▶ When finished recording **#**

Rerecording your name

The system plays your name as confirmation whenever a sender enters your mailbox number as a destination and when you enter your mailbox. You recorded your name the first time you used the system.

To rerecord your name:

- ▶ Select Personal Options **4**
- ▶ Select Greetings **3**
- ▶ Select Record Your Name **3**
- ▶ Record your name
- ▶ When finished recording **#**

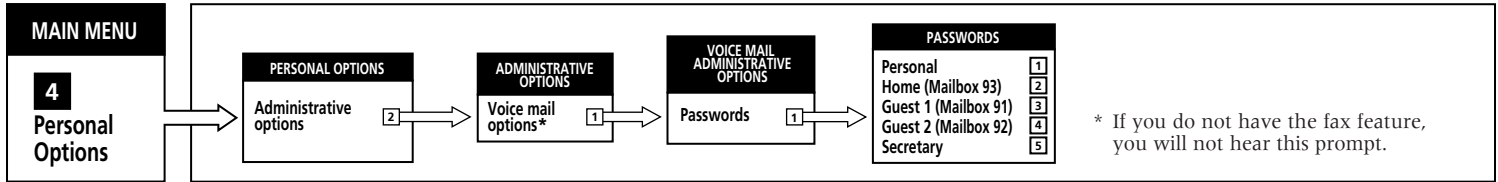

You selected a personal password when you set up your mailbox. You may change your password at any time and also add the following additional passwords:

- ◇ • **Home password.** This password enables your family to send and receive messages in the same manner as a guest. The Octel system plays messages from home before all others.
- ◇ • **Guest passwords.** A guest password enables callers to exchange messages with you as if they were users. Guests hear only those messages you send to them. They cannot exchange messages with other users through your mailbox.

You can have two guest passwords at any time. To change guests, simply change the guest password and give the new one to the new guest. The former guest's messages will be erased automatically.

- **Secretary password.** A secretary password enables someone you designate to enter your mailbox and obtain envelope information for the messages that are not from home. If you are unable to access the Octel system, a person with the secretary password can tell you who left messages.

Passwords can contain up to 15 characters; your system manager specifies the minimum length. Create passwords that are easy to remember but difficult for others to guess. For example, do not use your telephone number, because it is easy to guess. Each password you create must be different; you and your guests cannot have the same password.

TIP: Using guest mailboxes

Guest 1 is mailbox 91, Guest 2 is mailbox 92, and Home is mailbox 93. Use these destinations as you would ordinary mailbox numbers—for example, by adding them to personal group lists.

Changing or creating a password

- ▶ Select Personal Options **4**
- ▶ Select Administrative Options **2**
- ◇ ▶ Select Voice Mail Options **1**
- ▶ Select Passwords **1**
- ▶ Enter the type of password:
 - Personal password **1**
 - Home password **2**
 - Guest password **3** or **4**
 - Secretary password **5**
- ▶ Enter a password containing up to 15 digits
- ▶ When finished entering password **#**

Hearing your current password

To hear the current password, press **0** immediately after you identify the type of password to change.

◇ Explaining how to use guest and home passwords

You can give guest or home passwords to others so they can hear messages you sent to them and send messages to you. Instruct your guest how to use the system, as follows:

- ▶ Call the Octel system telephone number
- ▶ Press **#** during or after the greeting
- ▶ Enter your mailbox number
- ▶ Enter the password that you assigned to the guest or home mailbox
- ▶ Review messages from you and send you messages before disconnecting

◇ Replying to guest or home messages

Reply to messages from persons using guest or home passwords as you would any other message—that is, press **8** after reviewing the message.

CREATING AND MANAGING PERSONAL GROUP LISTS

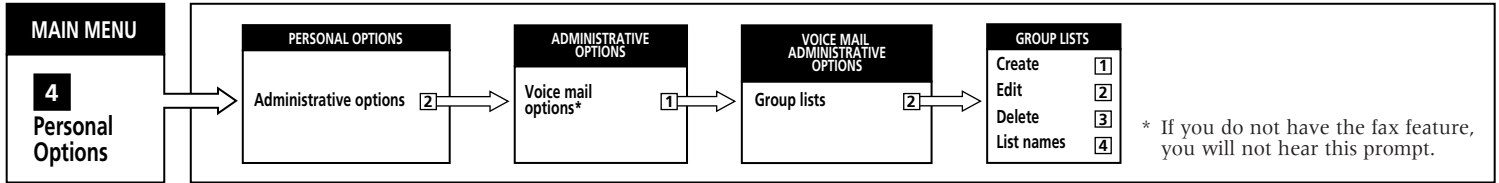

- ◇ If you send messages to the same group of people regularly, create personal group lists containing up to 25 mailbox numbers or network addresses. Personal group lists save time by enabling you to send messages to all members of the list at once. You can create multiple personal group lists.

For additional options related to managing distribution lists, see “Sending messages to large groups of people,” page 68.

◇ Creating personal group lists

- ▶ Select Personal Options **4**
- ▶ Select Administrative Options **2**
- ◇ ▶ Select Voice Mail Options **1**
- ▶ Select Group Lists **2**
- ▶ Select Create a List **1**
- ▶ Enter a two-digit number for the list: 11–25
- ▶ Record the list name—for example, “Regional Sales Managers”
- ▶ Enter the mailbox number/network address or spell the name of each person on the list; Guest 1 is mailbox 91, Guest 2 is mailbox 92 and Home is mailbox 93
- ▶ When finished, to exit and save the list *****

◇ Editing a personal group list

To add or delete a mailbox from a list:

- ▶ Select Personal Options **4**
- ▶ Select Administrative Options **2**
- ◇ ▶ Select Voice Mail Options **1**
- ▶ Select Group Lists **2**
- ▶ Select Edit List **2**
- ▶ Enter the list number
- ▶ Enter the mailbox number/network address or spell the name you want to add or delete. If the number appeared on the list previously, the system deletes it. If the number did not appear on the list, the system adds it.
- ▶ Review all names on the list (optional) **1**
- ▶ Exit and save the list *****

◇ Deleting a personal group list

- ▶ Select Personal Options **4**
- ▶ Select Administrative Options **2**
- ◇ ▶ Select Voice Mail Options **1**
- ▶ Select Group Lists **2**
- ▶ Select Delete List **3**
- ▶ Enter the distribution list number
- ▶ Delete the list **2**

◇ Reviewing or renaming a list

To play the names of all your lists and optionally rename a list:

- ▶ Select Personal Options **4**
- ▶ Select Administrative Options **2**
- ◇ ▶ Select Voice Mail Options **1**
- ▶ Select Group Lists **2**
- ▶ Select Names of Lists **4**
- ▶ Select Review Names **1**
- or
- ▶ Select Rename List **2**

SELECTING PROMPT LEVEL

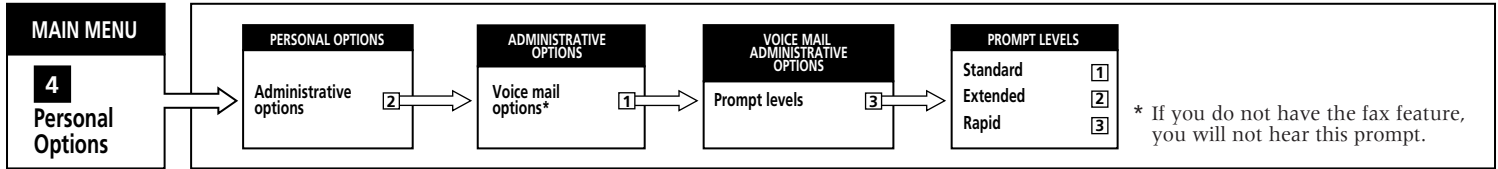

The Octel system provides three options for the level of prompting:

- **Standard** prompts, the default for new users, guide you through basic review and send functions. You can select all other functions by pressing the appropriate keys, even though you are not prompted to do so.
- **Extended** prompts give more detailed instructions and cover all features.
- **Rapid** prompts cover all features very briefly. They allow you to use the system more quickly after you are familiar with its capabilities.

Selecting prompt level

- ▶ Select Personal Options 4
- ▶ Select Administrative Options 2
- ◊ ▶ Select Voice Mail Options 1
- ▶ Select Prompt Levels 3
- ▶ Enter the level
 - Standard prompts 1
 - Extended prompts 2
 - Rapid prompts 3

NOTE: You can select most options before the prompt is complete. The system does not allow you to interrupt certain prompts, such as name confirmation and error messages.

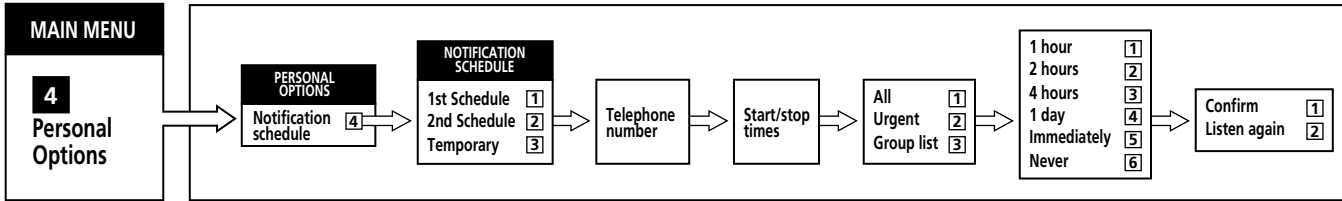

◇ The Octel system can call you at a designated telephone number to notify you when new messages arrive in your mailbox. You can tell the system to notify you when a message is received or after a specified time period. You may also establish separate notification schedules for urgent and non-urgent messages.

Outcall notification is helpful if you are out of the office frequently and want to be notified of new messages on a pager or cellular telephone or if you want to be notified of messages after hours or on weekends.

You may set up one or two schedules. For example, you might use one schedule for daytime notification to a pager or cellular telephone from 9 a.m. to 5 p.m. and another schedule for time at home from 7:00 to 10:30 p.m. Your weekend schedule applies on company holidays.

You may also set a temporary schedule, which overrides your other schedules.

◇ Setting your standard notification schedules

- ▶ Select Personal Options **4**
- ▶ Select Notification Schedule **4**
- ▶ Select the schedule you are creating or updating:
 - First schedule **1**
 - Second schedule **2**
 - Temporary schedule
(see “Setting up a temporary schedule,” page 52) **3**
- ▶ Select **1** to update or **2** to continue the schedule
- ▶ Enter the telephone number or extension the system should call to notify you, including the area code (or STD code if you are in the UK) if different from that of the system

Your system manager can tell you whether you need to enter a **9** or **1** before the telephone number. You may be restricted from entering certain telephone numbers.

- ▶ Enter the range of times you will accept notification calls during weekdays:
 - Beginning time—for example, 7:00 is **7 0 0** and 10:15 is **1 0 1 5**
 - Ending time
1 for a.m. or **2** for p.m.
- ▶ Enter the range of times you will accept notification calls during weekends:
 - Beginning time—for example, 7:00 is **7 0 0** and 10:15 is **1 0 1 5**
 - Ending time
1 for a.m. or **2** for p.m.
(continued on the next page)

- ▶ Enter the type of messages for which the notification applies:
 - All messages 1
 - Urgent messages only 2
 - Messages from members of a specified group list 3
- ▶ Enter the notification interval:
 - 1 hour 1
 - 2 hours 2
 - 4 hours 3
 - 1 day 4
 - Immediately 5
 - Never 6
- ▶ Accept the schedule 1
- or
- ▶ Review the schedule 2

TIP: Using a pager with outcalling

Ask your system manager to enable outcalls to a pager. Once this feature is enabled, the first schedule becomes your pager schedule.

◇ **Setting up a temporary schedule**

Your temporary schedule overrides the other two schedules for the number of days you specify. The other schedules are reinstated when the temporary schedule expires.

Set up a temporary schedule as you would an ordinary schedule. There is one additional prompt: After you enter **3** to indicate that the schedule is temporary, the system asks for the number of days the schedule should apply.

TURNING OUTCALL NOTIFICATION ON OR OFF

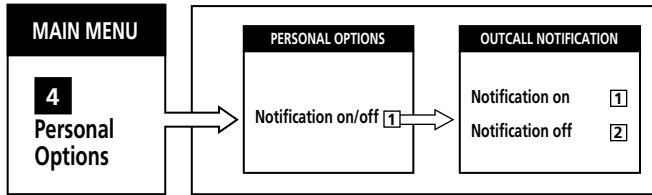

To turn outcall notification on:

- ▶ Select Personal Options **4**
 - ▶ Select Notification On/Off **1**
 - ▶ Turn notification on **1**
- or
- ▶ Turn notification off **2**

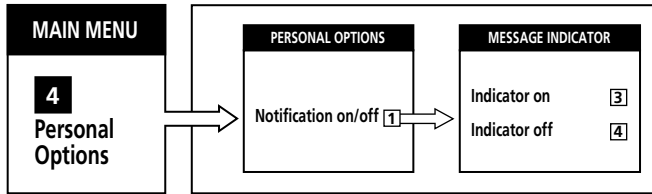

◇ The system can provide message notification via a message-waiting indicator. The arrival of new messages is signalled either by a light on your telephone or a stutter dial tone.

◇ Turning message-waiting indicator on/off

- ▶ Select Personal Options **4**
 - ▶ Select Notification On/Off **1**
 - ▶ Turn indicator on **3**
- or
- ▶ Turn indicator off **4**

NOTE: *If your message-waiting indicator is not activated when messages are in your mailbox, check to be sure that you have turned on the indicator.*

SETTING DATE AND TIME PLAYBACK

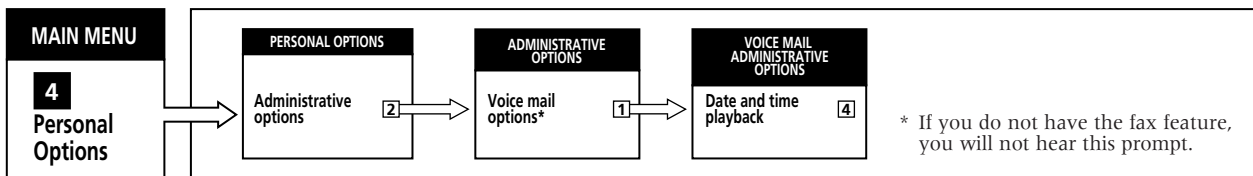

- ◇ The system can play the date and time a message was received before playing the message. For archived messages, the date and time may reflect when the message was received or saved, at the option of your system manager.

3◇ Turning date and time playback on/off

- ▶ Select Personal Options **4**
- ▶ Select Administrative Options **2**
- ◇ ▶ Select Voice Mail Options **1**
- ▶ Select Date and Time Playback **4**
- ▶ Turn date and time playback on **1**
- or
- ▶ Turn date and time playback off **2**

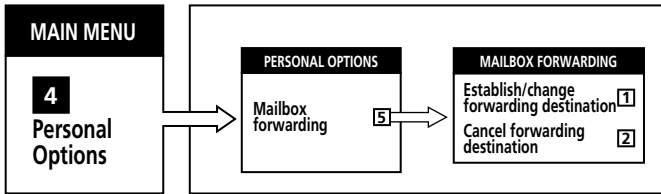

◇ If your system has networking software, you can forward messages from your mailbox to a designated mailbox on another Octel system. If you work in a branch office, for example, you can forward messages you receive at headquarters to your local Octel system. Then you won't need to call the Octel system at company headquarters to check for messages.

NOTE: *Networked messages sent to your forwarding mailbox will not be forwarded. Therefore, you should check the forwarding mailbox periodically for such messages.*

To forward messages, set up the mailbox by recording your name, greeting and password; then define the forwarding mailbox destination.

Messages already in your mailbox at the time you establish forwarding are not forwarded. The system reminds you that your mailbox is forwarding each time you enter your mailbox.

◇ Setting up mailbox forwarding

- ▶ Call the system on which your system manager created your forwarding mailbox
- ▶ Enter your mailbox
- ▶ Record your name, personal greeting and password (*see "Setting up your Octel mailbox, page 2"*)
- ▶ Select Personal Options 4
- ▶ Select Mailbox Forwarding 5
- ▶ Select Establish the Forwarding Destination 1
- ▶ Enter the network node address and the forwarding destination mailbox number
- ▶ Confirm that the information is correct #

◇ **Changing the destination or
cancelling forwarding**

- ▶ Select Personal Options **4**
- ▶ Select Mailbox Forwarding **5**
- ▶ Select Change the Destination **1**
- or
- ▶ Select Cancel Mailbox Forwarding **2**

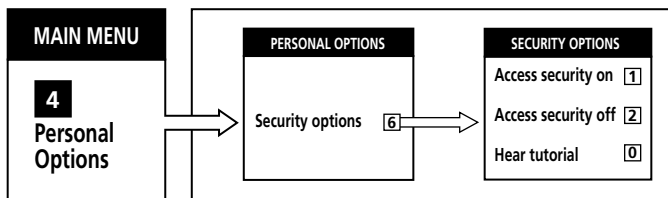

◇ If you are concerned about the security of your mailbox, you can set up the Octel system to let you know if someone else entered your mailbox. Ask your system manager if this feature is available to you.

If you activate access security, the system prompts you to record your name and the time of day each time you enter your mailbox. The system then plays back the recording made the last time the mailbox was entered. If a name and time of entry were not recorded during the previous session, you will hear silence or “The last mailbox access was by *skipped*.” If this occurs, you should change your password and notify your system manager immediately.

◇ Turning access security on

- ▶ Select Personal Options **4**
- ▶ Select Security Options **6**
- ▶ Turn access security on **1**
- ▶ Record your name and the time
- ▶ When finished recording **#**

◇ Turning access security off

- ▶ Select Personal Options **4**
- ▶ Select Security Options **6**
- ▶ Turn access security off **2**

CHAPTER 8

USING SPECIAL FEATURES

In this chapter:

- Accessing applications
- Reviewing and sending Bulletin Broadcast messages
- Recording a meeting
- Sending messages to large groups of people
- Sharing a telephone
- Sending messages outside your company's network

◇ All features in this chapter are optional.

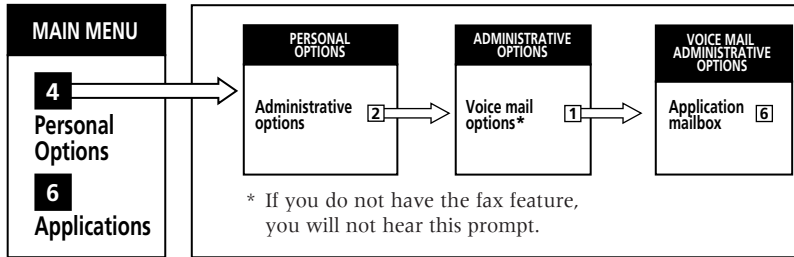

- ◇ Your Octel system may include application mailboxes that provide information or access to a database—for example, benefit enrollment periods, conference room availability, stock prices or job openings. You may be able to visit an application directly from your mailbox.

◇ Designating the application mailbox you want to hear

Your system manager already may have set up an application mailbox for you to hear. If not, you may be able to designate one application mailbox yourself. See your system manager for a list of application mailboxes.

To set up or change the preferred application mailbox yourself:

- ▶ Select Personal Options 4
- ▶ Select Administrative Options 2
- ◇ ▶ Select Voice Mail Options 1
- ▶ Select Application Mailbox 6
- ▶ Enter the number of the preferred application mailbox

◇ Listening to applications

- ▶ Select Applications 6
- ▶ Select an application from the menu supplied by your system manager
- or
- ▶ Listen to the one application you or the system manager designated

After the application is finished, the system transfers you back to the main menu of your mailbox.

REVIEWING AND SENDING BULLETIN BROADCAST MESSAGES

REVIEWING BULLETIN BROADCASTS

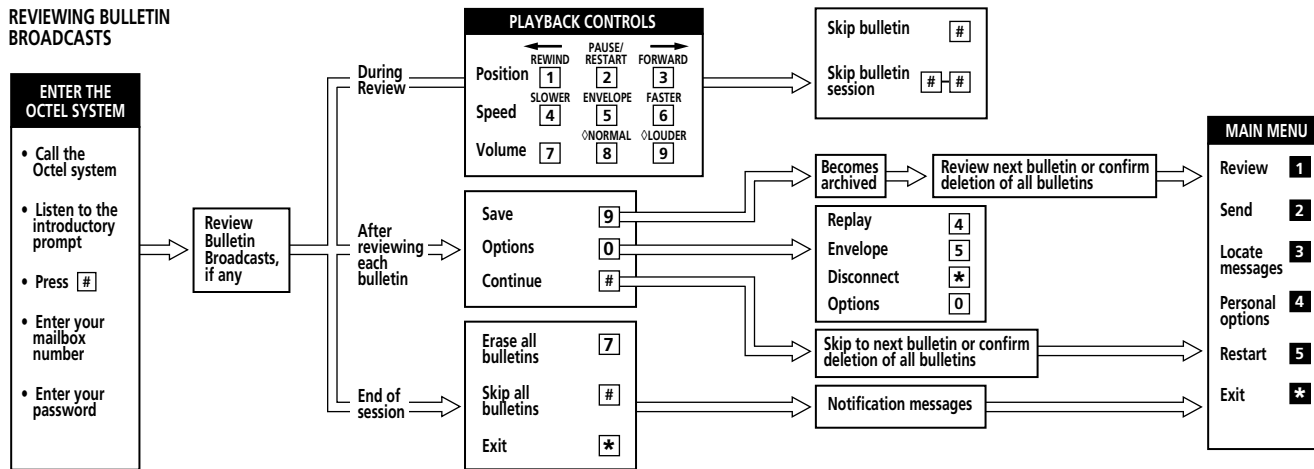

SENDING BULLETIN BROADCASTS

(Check with your system manager to see if you have this capability.)

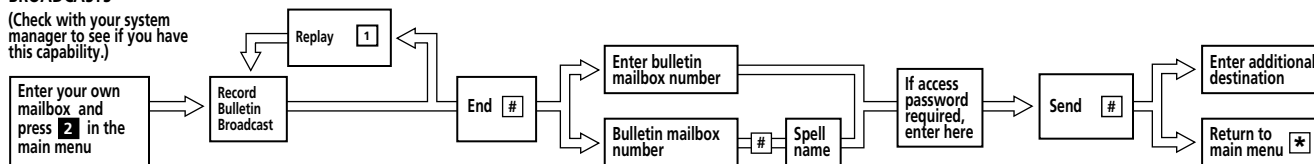

- ◇ Bulletin Broadcasts play to a select group of users after system broadcasts and before all other messages.

The system manager specifies the group of users who receive messages from a bulletin mailbox.

Bulletin Broadcasts do not trigger message notification.

◇ Reviewing Bulletin Broadcasts

Most message review functions and all playback controls are available during review of Bulletin Broadcasts.

During review:

- ▶ To skip bulletin #
- ▶ To skip all bulletins # - #

After reviewing each bulletin:

- ▶ To save 9
- ▶ To listen to next bulletin without responding to the current one #

At end of bulletin session:

- ▶ To erase all bulletins 7
- ▶ To skip all bulletins #

If your mailbox is full, you may receive a Bulletin Broadcast, but you will not be able to save it until you free space by deleting unneeded messages.

◇ Sending Bulletin Broadcasts

Before sending a Bulletin Broadcast, contact your system manager to obtain the bulletin mailbox number and password.

To send a Bulletin Broadcast:

- ▶ Select Send Messages 2
- ▶ Record your message
- ▶ When finished recording #
- ▶ Enter the bulletin mailbox number or press # to spell its name
(see page 13)
- ◇ ▶ Enter the access password

- ▶ Select one or both of the following delivery options (optional):

Future delivery 4
(on your own system or across the OctelNet™ network to a bulletin mailbox on another system)

Message confirmation 3
(use only when sending a message to a bulletin mailbox on another system)

- ▶ Send the message #

The system will tell you how many days the message will be saved before being deleted automatically.

◇ **Deleting a bulletin that you recorded**

- ▶ Select Locate Messages **3**
- ▶ Select Locate Messages Sent **1**
- ▶ Enter the bulletin mailbox number
- ▶ Listen to each bulletin and
select an action:
 - Retain **1**
 - Delete **2**

RECORDING A MEETING

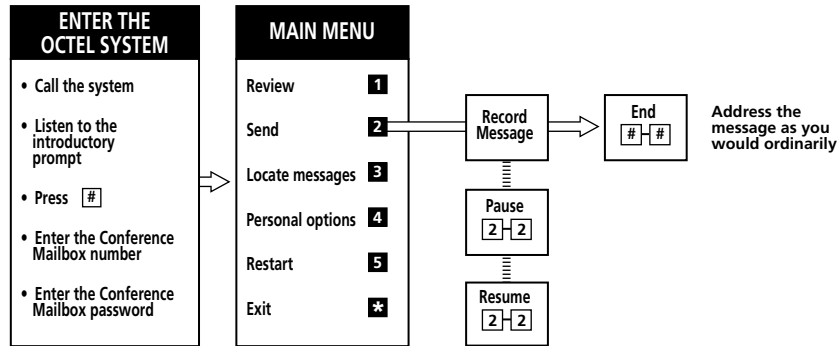

NOTE: Message Review (**1**) is not allowed during SEND.

- ◇ You can use the Octel system with a speaker phone to record a meeting and then send the recorded meeting to selected users as a voice message. This process enables those who did not attend to hear the proceedings.

Before recording a meeting, ask your system manager for a Conference Mailbox number, password and the maximum allowed recording time.

◇ Recording and sending the proceedings of a meeting

- ▶ Call the Octel system using a speaker phone
- ▶ Press **#** to indicate that you have a mailbox on the system
- ▶ Enter the Conference Mailbox number
- ▶ Enter the Conference Mailbox password
- ▶ Select Send **2**
- ▶ Begin recording the meeting

If insufficient storage space is available to save the maximum message length, the system informs you and does not let you record.

- ▶ Conduct the meeting
 - To pause or resume recording **2** - **2**
- ▶ When finished recording **#** - **#**
- ▶ Enter a mailbox or distribution list number or press **#** to spell the name
- ▶ Enter delivery options
- ▶ Send **#**

TIP: Preventing accidental pausing and erasures

*To prevent talk off or accidents caused by inadvertent key pressing, the Octel system requires that you press **2** - **2**, **#** - **#** or *** - *** to pause, end the recording or cancel, respectively. Pressing these keys once has no effect when you are using a Conference Mailbox.*

◇ Reviewing meeting messages

Unlike ordinary messages, meeting proceedings cannot be reviewed immediately after you end the recording.

To review meeting proceedings:

- ▶ Re-enter the Conference Mailbox **1**
- ▶ Select Review **1**
- ▶ Listen to the message **1**

If multiple new messages are in the mailbox, press **#** to skip to your message.

◇ Erasing recorded meetings

- ▶ Enter the Conference Mailbox **1**
- ▶ Select Review **1**
- ▶ Go to end of message **3** - **3**
- ▶ Erase **7**

TIPS: Maintaining confidentiality

Mark the message as private if you want to prevent the recipient from sending a copy of the message to someone else.

Conserving storage space

Messages are saved in the Conference Mailbox. Erase all unneeded messages promptly to free up storage space for subsequent meetings.

Sending Conference Mailbox messages to other Octel systems

The network port is tied up for the length of the message.

Voice Bulletin Boards (Information Center Mailboxes) cannot receive networked messages.

Some systems to which you send a Conference Mailbox message may only be able to receive messages that are no longer than two and a half hours long. Check with your system manager before you record your meeting.

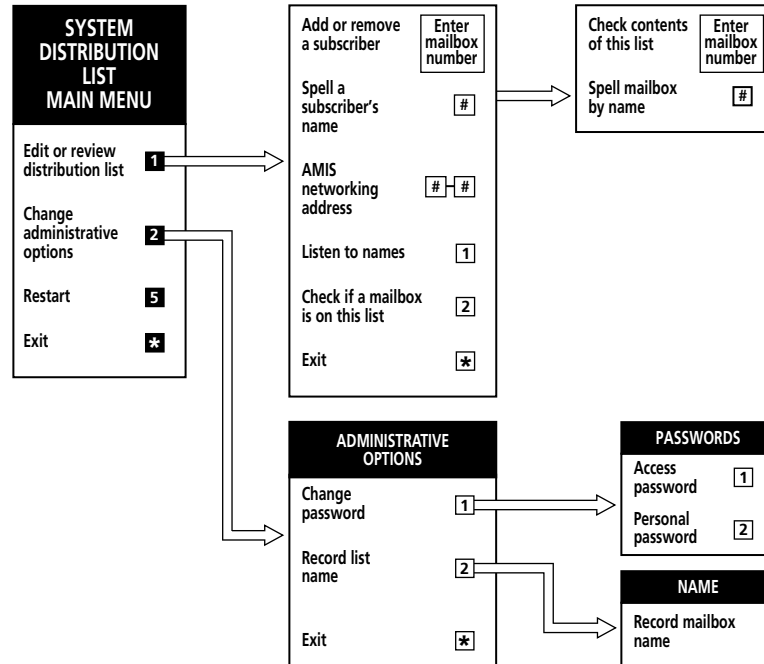

-
- ◇ You can use System Distribution Lists to send a message to many people at once. System Distribution Lists can be managed by system managers via the system manager terminal or via a touchtone telephone by users designated as mailbox managers.

Each System Distribution List can contain up to 300 entries, including individual users' mailbox numbers, network addresses, AMIS networking addresses (*see page 70*), alias addresses and other distribution list numbers. A fully loaded System Distribution List lets you send a message to more than 18,000 people at the same time.

NOTE: *If you select delivery options for a message you address to a distribution list, the system does not apply them to AMIS network destinations. AMIS does not support delivery options.*

◇ Entering a System Distribution List Mailbox

- ▶ Call the Octel system
- ▶ Press **#** to indicate that you have a mailbox on the system
- ▶ Enter the System Distribution List number
- ▶ Enter the System Distribution List password

◇ **Adding and removing users and other lists from a System Distribution List**

- ▶ Enter the System Distribution List
- ▶ Select Edit or Review **1**
- ▶ Enter the mailbox number of the user or distribution list you want to add or remove, or press **#** to spell the name (*see “Spelling a name,” page 13*)

If you are adding to a distribution list that requires an access password, delete the password before adding. After adding, ask the mailbox manager to reassign the password.

◇ **Adding and removing AMIS networking addresses from a System Distribution List**

- ▶ Enter the System Distribution List
- ▶ Select Edit or Review **1**
- ▶ Indicate you are entering an AMIS networking address **#** - **#**
- ▶ Enter the AMIS networking address

◇ Listening to the names in a System Distribution List

To hear the names of users and other distribution lists in a System Distribution List:

- ▶ Enter the System Distribution List **1**
- ▶ Select Edit or Review **1**
- ▶ Select Listen to Names **1**

◇ Locating a specific mailbox or distribution list in the System Distribution List

- ▶ Enter the System Distribution List **1**
- ▶ Select Edit or Review **1**
- ▶ Select Check If Mailbox Is on the List **2**
- ▶ Enter the mailbox number or press **#** to spell its name

◇ Changing passwords

Two passwords are available for System Distribution List:

- Access passwords, which may be required to send messages to a particular System Distribution List
- Personal passwords, which enable the mailbox manager to enter a System Distribution List and alter its content

To change passwords:

- ▶ Enter the System Distribution List
- ▶ Select Administrative Options **2**
- ▶ Select Change Password **1**
- ▶ Select password type:
 - Access **1**
 - Personal **2**
- ▶ Enter the new password

◇ **Changing the name of a
System Distribution List**

- ▶ Enter the System Distribution List
- ▶ Select Administrative Options
- ▶ Select Record List Name
- ▶ Record name

2

2

SHARING A TELEPHONE

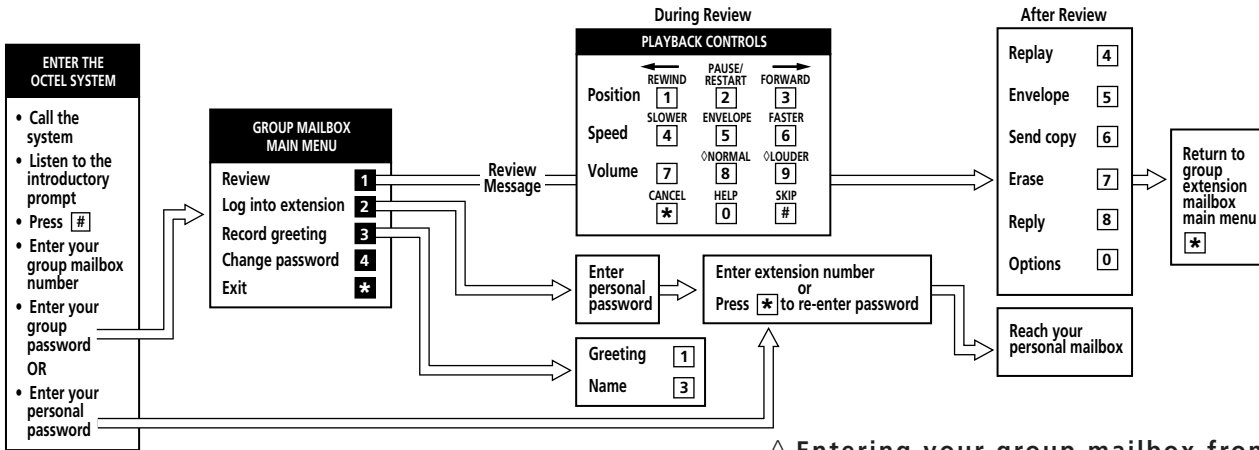

◇ Users who share the same telephone have two types of mailboxes. One is a personal, private mailbox for sending and receiving messages. The other is a group mailbox, which is available for callers who do not select a personal mailbox destination from the menu. Both of these mailbox types are part of Octel system features called Extension Mailbox (for businesses and for educational institutions).

◇ Entering your group mailbox from your shared telephone

- ▶ Call the Octel system
- ◇ ▶ Press [#] to indicate that you have a mailbox on the system
- ◇ ▶ Enter the group mailbox number

NOTE: *The above two steps are not required if your extension is integrated with your mailbox. See your system manager if you have questions.*

- ▶ Enter your group password

◇ **Entering your group mailbox from a telephone other than your shared telephone**

- ▶ Call the Octel system
- ▶ Press **#** to indicate that you have a mailbox on the system
- ▶ Enter your group mailbox number
- ▶ Enter your group password

◇ **Entering your personal mailbox from your shared telephone**

- ▶ Call the Octel system
- ◇ ▶ Press **#** to indicate that you have a mailbox on the system
- ◇ ▶ Enter the group mailbox number

NOTE: *The above two steps are not required if your extension is integrated with your mailbox. See your system manager if you have questions.*

- ▶ Enter your personal password
- ▶ Enter your extension number (1–9)

◇ **Entering your personal mailbox from a telephone other than your shared telephone**

- ▶ Call the Octel system
- ▶ Press **#** to indicate that you have a mailbox on the system
- ▶ Enter the group mailbox number
- ▶ Enter your personal password
- ▶ Enter your extension number (1–9)

◇ **Reviewing a message in your group mailbox**

- ▶ Enter your group mailbox
 - ▶ Select Review **1**
 - ▶ Listen to the message
(See “Using playback controls,” page 27)
 - ▶ At end of message, send to the appropriate extension, if desired:
 - Select Send Copy **6**
 - Record introduction
 - When finished recording **#**
 - Enter group mailbox number, then enter the extension number
 - Send the copy **#**
- or
- ▶ Skip message if it is not for you **#**

NOTE: *You cannot save messages in a group mailbox. You must skip or forward them.*

◇ **Reviewing a message in your personal mailbox**

To review a message in your personal mailbox, enter your personal mailbox, then follow the instructions in “Listening to messages,” page 21.

◇ **Sending a message from your personal mailbox**

- ▶ Enter your personal mailbox
- ▶ Select Record **2**
- ▶ Record your message
- ▶ When finished recording **#**
- ▶ Address the message
 - Enter group mailbox number, then enter the extension number
 - or
 - Enter personal mailbox number or press **#** to spell name
- ▶ Enter delivery options (see page 14)
- ▶ Send **#**

NOTE: For security reasons, your system manager may not allow you to receive messages in the group mailbox or change the password. In this case, you will not be able to perform the following tasks.

◇ Recording your group mailbox greeting

- ▶ Enter the group mailbox
- ▶ Select Record Greeting **3**
- ▶ Select Greeting **1**
- ▶ Record the greeting
- ▶ When finished recording **#**

Suggested greeting:

“We can’t take your call right now. To leave a message for Andrew, press **1**; for John, press **2**; for Barbara, press **3**; and for Mary, press **4**.”

◇ Recording your group mailbox name

- ▶ Enter your group mailbox
- ▶ Select Record Greeting **3**
- ▶ Select Name **3**
- ▶ Record the name
- ▶ When finished recording **#**

◇ Changing your group mailbox password

- ▶ Enter the group mailbox
- ▶ Select Change Password **4**
- ▶ Enter the new password

TIP: Being a considerate group mailbox member

- *Decide as a group what the group greeting should say, and talk with other members before changing the greeting*
 - *Change the group mailbox password occasionally, telling every member before the change*
 - *Always take the time to forward messages in the group mailbox to the intended recipient's personal mailbox*
 - *After you send a copy, erase the original; never erase a message in a group mailbox without first sending a copy to the intended recipient*
-

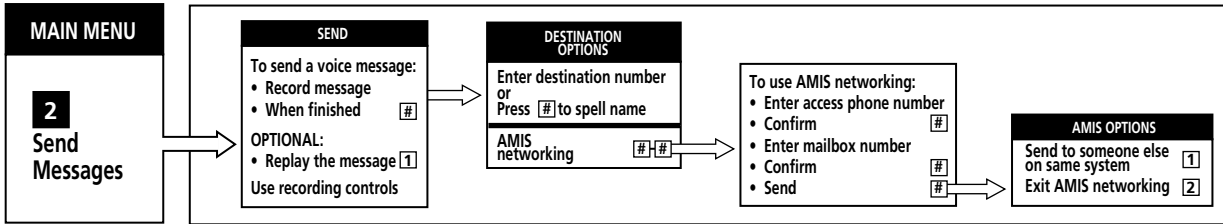

◇ You may send messages that you record to non-Octel systems or Octel systems outside your company's Octel network. The system uses AMIS networking to send to these destinations.

Sending a message using AMIS networking

- ▶ Record your message (*see page 11*)
- ▶ When finished recording #
- ▶ Indicate you are using AMIS networking # - #
- ▶ Enter the recipient's AMIS access phone number
- ▶ Confirm the access phone number #
- ▶ Enter the recipient's mailbox number
- ▶ Confirm the mailbox number #
- ▶ Send the message #

NOTE: *Delivery options are not available with AMIS networking.*

CHAPTER 9

EXPLAINING THE SYSTEM TO OUTSIDE CALLERS

In this chapter:

- Sending fax messages
- Leaving voice messages

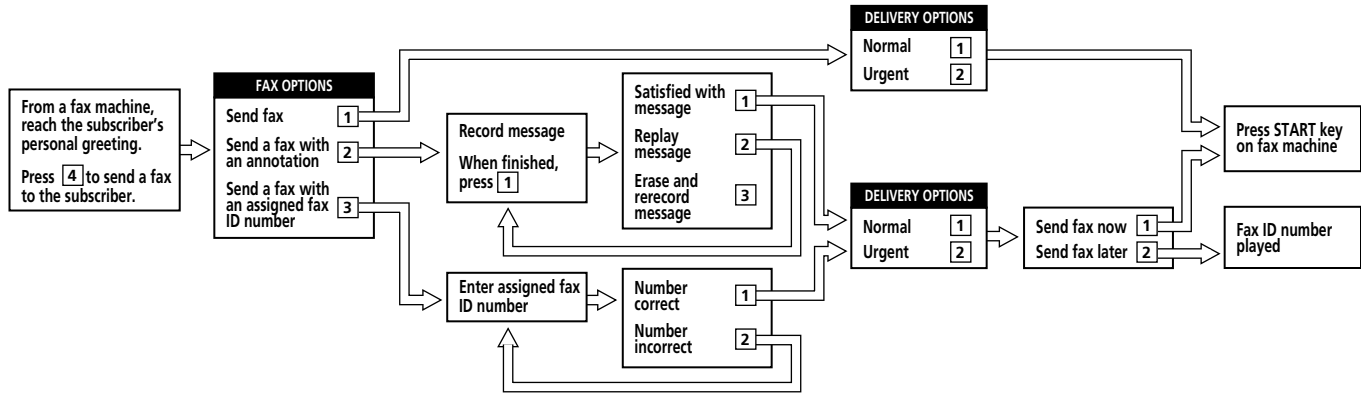

SENDING FAX MESSAGES

- ◇ Callers can send a fax to your voice and fax mailbox. They also may record a voice message, or voice annotation, to precede the fax.

Voice annotations provide information about the fax without having to make notations on the fax itself. A caller can record a voice annotation and send the fax at the same time, or the caller can record and send them separately.

If the caller is going to send the fax separately, he or she records the voice annotation first using any telephone, not the fax machine phone. In this case, the system gives a fax identification number to the caller. When sending the fax later, the caller must enter this identification number to link the fax and the voice annotation.

TIP: Remembering the fax identification number

Be sure to have a pencil handy when the system plays the fax identification number. Write down the number so you won't forget it.

To send a fax to a voice and fax mailbox from a fax device, perform the following steps before placing the document in the feeder tray:

- ▶ Lift the handset of the fax machine
- ▶ Call or be forwarded to your mailbox
- ▶ During the greeting, press **4** for fax options
- ▶ Listen to the spoken prompts and follow directions

LEAVING VOICE MESSAGES

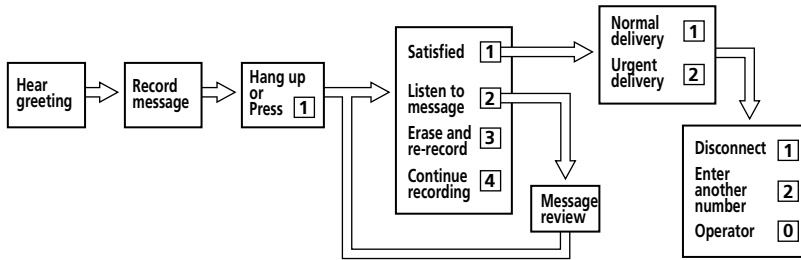

When outside callers dial your number, they are either forwarded directly to your voice and fax mailbox or asked to dial your extension. Then they hear your personal greeting.

TIP: Skipping your greeting

Tell frequent callers they may skip your greeting by pressing the # key.

When callers have recorded a message, they may hang up or press **1** for more options. If they press **1**, the system gives them the following options:

- ▶ If satisfied with the message **1**
- ▶ To listen to the message **2**
- ▶ To erase and rerecord **3**

Callers can continue recording after listening to the message by pressing **4**.

When the caller presses **1**, he or she is prompted for delivery options:

- ▶ Normal delivery **1**
- ▶ Urgent delivery **2**

When the caller is finished, he or she can hang up, enter another number or press **0** for assistance.

GLOSSARY

AMIS. Networking software used to send messages to non-Octel voice mail systems and to Octel systems outside of your company's network.

Archived messages. Messages saved for future use.

Auto-print. Option for printing all faxes received in your mailbox to a fax device that you have specified.

Caller. Someone whom the system does not recognize as a user.

Delivery options. Feature that allows you to mark messages as private or urgent, and to specify future delivery.

Envelope information. Tells who sent the message, the date and time sent, and message length.

Extended-absence greeting. Advises callers that you are away from the office and may be checking your mailbox infrequently.

Guest mailbox. A portion of your mailbox that you can designate for someone who is not a

user, but with whom you communicate frequently, such as a vendor.

Home mailbox. A portion of your mailbox that you can designate for family members to exchange messages with you.

Mailbox. A portion of the Octel system where you can send and receive voice messages and, if you have the fax capability, fax messages.

Main menu. The first menu you hear after you enter your password; in this manual, main menu options are indicated like this: **4**.

Menu. A related set of system features from which you can choose; all menu items are spoken if you have selected the extended or rapid-prompt level.

Networked messages. Messages sent to remote messaging systems.

OctelNet. Software used to send messages to your company's remote Octel systems.

Password. Security code that allows access to your mailbox.

Personal group list. Contains up to 25 mailbox numbers or network addresses, saving you time by enabling you to send messages to all members of the list at once. Your mailbox will support up to 15 personal group lists.

Playback controls. Keys you press to control volume and speed of message playback.

Power keys. Keys you can use to complete operations more quickly: **[*]** to cancel an operation, **[#]** to proceed immediately to the next step, and **[0]** to get help.

Recording controls. Keys you press to pause, replay, or rerecord some or all of a message you are recording.

Reply. Respond directly to another user's message by pressing **[8]** to leave a message.

Standard greeting. A prerecorded greeting that tells callers they may leave a message.

Subscriber. Someone who has a mailbox on the Octel system. Also known as a user.

System manager. Person who manages your Octel system.

System Distribution List. Enables you to send a message to more than 18,000 people at the same time; contains up to 300 entries, including individual subscribers' mailbox numbers, network addresses, AMIS networking addresses, alias addresses, and other distribution list numbers.

Unheard message. A voice message in your mailbox that you have not listened to or a fax you have not printed.

User. Someone who has a mailbox on the Octel system. Also known as a subscriber.

Voice annotation. The voice message that a caller can record and "attach" to a fax message.

Voice bulletin board. A mailbox both callers and users call to hear information, such as directions to the company and job postings. A password may be required for entry. Also known as Information Center Mailbox.

INDEX

A

- Access security 58
- Addressing a message 13
- AMIS 69, 70, 78
- Application mailbox 60
- Archived messages 21
- Automatic printing of all faxes 31

B

- Broadcast messages 23, 61
- Bulletin Broadcasts 61

C

- Calling the system 3
- Calling the system from a pay phone 3
- Cancelling an operation 6
- Cancelling review 22
- Conference Mailbox 65
- Confirmation of delivery 15, 23
- Confirmation of receipt 15
- Credit card calls 3

D

- Date and time playback 55
- Delivery options
 - Confirmation of receipt 15
 - Future delivery 16
 - Notification of non-receipt 15
 - Private 14
 - Selecting 14
 - Urgent 15
- Dial-by-Name 13
- Distribution list
 - Personal group list 47
 - System distribution list 69

E

- Entering the system 3
- Envelope information 22
- Erasing 6, 26
- Etiquette, group mailboxes 77
- Exiting the system 4
- Extended prompts 49

Extended-absence block 23, 43

Extended-absence greeting 43

Extension Mailbox 73

F

Fast forwarding 12

Fax messages

 Hearing about 32

 Printing 33

 Printing automatically 30, 31

Forwarding copies of messages 25

Forwarding messages to other systems 56

Future delivery 16

G

Greetings 41

 Extended-absence 43

 Group mailbox 73

 Personal 2, 41, 42

 Standard 2, 41

Group mailboxes 73

Guest mailboxes 44

H

Help 7

Home mailboxes 44

Home messages 21, 44

I

Introductions, removing other 25

L

Locating messages you have sent 37

Locating messages sent to you 38

M

Mailboxes

 Entering 3

 Forwarding 56

 Maximum number of messages 17

 Setting up 2

Meetings, recording 65

Message confirmation 15

Message notification 50, 54

Message-waiting indicator 54

Messages

- Automatic deletion of 26
- Blocking during extended absences 43
- Erasing 26
- Forwarding copy 25
- Forwarding to other systems 56
- Replaying 22
- Responding to 24
- Reviewing 21
- Saving 26
- Sending 17
- Sending copy 25
- Skipping 22

Mistake in destination address 6

N

- Name recording 43
- No-answer greeting 41
- Non-delivery of messages 23
- Notification of non-receipt 15

Notification schedule 50

O

- Outcall attempts 23
- Outcall notification 50, 53
- Outside callers, explaining system to 34, 79

P

- Pager, outcall notification 50, 52
- Passwords 2, 44
- Pausing 11, 12
- Personal greeting 2, 41
- Playback controls 27
- Power keys 5
- Primary printing destination 30
- Private messages 14
- Prompt level, changing 49
- Prompts, interrupting 49

R

Rapid prompts 49

Recording a meeting 65

Recording a voice message 11

Recording controls 12

Replaying a message 22

Replying to a message 24

Rerecording a message 11

Restarting 4

Reviewing unheard voice messages 21

Rewinding 12

S

Saving 26

Security 58

Sending a copy 25

Sending a message 17

Setting up the mailbox 2

Sharing a telephone 73

Skipping messages 22

Skipping prompts 8, 49

Spelling a name 13

Standard greeting 2, 41

Standard prompts 49

T

Telephone, sharing 73

Time zones 14

U

Urgent messages 15

V

Voice annotation 34, 81